

Westfield Parish Council



The Oval Office, St Peter's Business Park
Westfield, BA3 3BX
Phone: 01761 410669
Email: council@westfieldparishcouncil.co.uk

Chairman: Cllr P Wilkinson Parish Clerk: Ms L J Close FSLCC

Established 2011

All Council Meetings are open to the Public and Press

24th August 2023

TO: (a) **All Members of the Environment and Development Committee**
Cllrs Diana Cooper (Chair), Geoff Fuller, Ron Hopkins (Vice Chair), James Honess,
Eleanor Jackson, Paul Millard, Pat Williams.

(b) **All other Members of the Council for information**

Dear Councillor,

You are summoned to attend a meeting of the **Environment and Development Committee** of Westfield Parish Council on **Monday 11th September 2023 at 7pm at the Board Room, Oval Office, Cobblers Way, Westfield BA3 3BX.**

The meeting will consider the items set out below.

A handwritten signature in black ink, appearing to read 'LJ Close'.

Ms L J Close
Parish Clerk

Before the meeting there will be a 15-minute public session to enable residents of Westfield to ask questions, and make comments.

AGENDA

1. **Apologies for absence and to consider the reasons given** Council to receive apologies for absence and, if appropriate, to approve the reasons given.

2. **Declarations of interest and dispensations** Members to declare any interests they may have in agenda items, in accordance with the requirements of the Council's Code of Conduct. The Parish Council may consider agreeing a dispensation, providing the request is put in writing and the dispensation is allowed on the grounds set out in s.33 of the Localism Act 2011.
3. **Minutes of the last meeting** – To agree the minutes as a true and accurate record of the meeting held on 10th July 2023 **(Pages 1-4)**
4. **Neighbourhood Plan Review Working Group** verbal update
5. **Planning applications for consideration (no applications at time of agenda being printed)**
6. **Planning decisions (Page 5)**
7. **Mendip Local Plan Part II (Pages 6-7)**
8. **Speeding data collected on A367** Verbal update on request to B&NES for more speed indicator devices
9. **Recreation Ground – Norton Hill**
 - New Office – verbal update
 - Dogs on leads and no dogs in the play area signs **(Pages 8-9)**
 - Vandalism over the summer – basketball net damaged, graffiti on the basketball post and table tennis table, ground dug out in the play area.
10. **Recreation Ground – Westhill**
 - Changing Rooms – verbal update
 - Park Assistant Trial – Facebook feedback **(Pages 10-11)**
 - Vandalism over the summer – damage to hammock swing set and wet pour
11. **Waterside Valley**
 - Grass cutting – verbal update
12. **Events**
 - Grant Presentation Event – verbal update
 - 80th Anniversary of D-Day 6th June 2024 – **(Pages 12-16)**
 - Christmas Lights Switch On – 30th November 6.30pm – verbal update
13. **Barriers on the footpaths**
 - (1) Inner Elm Terrace / Wesley Ave and Woodpecker Ave / Lynton Road **(Pages 17-19)**
 - (2) End of Chaucer Road **(Page 20)**
 - (3) Linden Close **(Pages 21-24)**
14. **Love Parks Week and Survey (Pages 25-28)**
15. **Defibrillators update** – Westhill Recreation Ground and Elm Tree Avenue
16. **Communications – Facebook increase (Pages 29-30)**

17. Meeting with Victor da Cuna, CURO 16/8/23 Verbal update Cllr Jackson

To resolve that, under Section 100A(4) of the Local Government Act, 1972, the press and public be excluded from the meeting for the following item of business on the grounds that it involves the likely disclosure of exempt information falling within those paragraphs indicated in Part 1 of Schedule 12A of the Local Government Act 1972, as amended.

18. Quotes

- Bridges at Waterside Valley - update

Westfield Parish Council

Minutes of the Environment and Development Committee Meeting held in the boardroom at the Oval Office, Cobblers Way, Westfield on 10th July 2023 commencing at 7pm.

Present: Cllrs Diana Cooper (Chair), Geoff Fuller, James Honess, Ron Hopkins (Vice Chair), Eleanor Jackson, Paul Millard, Phil Wilkinson and Pat Williams

Also attending: Lesley Close, Parish Clerk, Tracey Stephens, Deputy Clerk, one member of the public

32. Apologies for absence and to consider the reasons given

There were no apologies for absence

33. Declarations of interest and dispensation

Cllr Jackson declared an interest in item 5 – Planning items for consideration as a member of the Church Council.

Cllr Williams declared an interest in item 16 – Grass cutting schedules as she lives at Fosseyway Gardens.

34. Minutes of the last meeting

Resolved: The minutes of the last meeting held on 12th June 2023 were agreed as a true record and signed by the Chair.

35. Neighbourhood Plan working group

Cllr Hopkins reported on the meeting that had taken place before this one. One resident attended and Councillors were asked if they knew anyone else that may be interested in being part of the working group. Cllr Hopkins advised he was to meet with BaNES officers and establish objectives. The next meeting is scheduled for Monday 18th September, 7pm.

36. Planning applications for consideration

There were no objections to the following:

23/02143/TPO	39a Nightingale Way	Lime Tree, TPO 533/35, reduce main canopy by up to 2m max. Reduce to areas/limbs further than max 2m, remove identified lower limbs, remove all epicormic growth from main stem, remove deadwood
23/02244/FUL	Byfields, Wells Road	Remove of existing single storey side extensions, part of the existing swimming pool and building and all the garage outbuildings. Construction of new single storey side extensions, a new car ort and a new Gym building (Resubmission).

Minutes subject to approval at the next meeting.

Signed Dated

23/02064/OUT, 60 Wells Road, Erection of 2no.dwellings on land to west of existing dwelling (Outline application with all matters reserved)

The committee objected to this application on the grounds of overdevelopment.

37. Planning Decisions

There were no planning decisions to note. Cllr Hopkins asked if there was any further information on enforcement in the area – specifically the caravan behind the Railway Inn. There was nothing to report – Cllr Jackson to chase it up with BaNES.

38. B&NES Local Plan: The Future of the Somer Valley and Surrounding Areas Consultation

There was to be a meeting – Somer Valley Area workshop – on 26th July. Cllr Hopkins to attend and report back to Council.

39. Somer Valley Links Project – Consultation from WECA

Cllr Hopkins to attend a consultation event on 12th July and report back to Council.

40. Reporting on speed data collected on A367 w/c 7th June

The data provided by cameras along the A367 was discussed.

Resolved: (1) to include the data in the Neighbourhood Plan Review, possibly requesting more speed signs.
(2) to ask BaNES how to go about getting more speed indicator signs as this seemed to slow traffic by the primary school.

41. Enterprise Zone

The response from Sophie Broadfield was noted.

42. The Extended Bio-Diversity Duty for Public Authorities

Resolved: to recommend the draft policy for adoption by the Parish Council.

43. Meeting with the Dog Warden 22nd June

Options to encourage people to keep their dogs on leads at the recreation grounds were discussed in detail.

Minutes subject to approval at the next meeting.

Signed Dated

Westfield Parish Council

- Resolved:** (1) to get a final cost for security to patrol Westhill at certain times of the day for up to 5 hours a week. This to be a trial for one month.
- (2) to delegate authority to Cllrs Cooper and Wilkinson to set a budget and approve the costings.
- (3) to investigate the possibility of someone going into schools to discuss with the children.

44. Recreation Ground – Norton Hill

New office – It was noted that we had received two tenders.

Resolved: to extend the deadline to the end of July

Grant for pitch improvements – an update was given. The Pitchpower inspection had been received and the funding application was due to be submitted.

45. Recreation Ground - Westhill

Changing Rooms – It was noted that Westhill Club’s Solicitors had submitted the paperwork to Land Registry and were waiting for a response.

46. Waterside Valley

Hedgerow improvements – A report was given on the meeting on site with Sonia Parsons of CPRE. There is to be a walk in the summer for volunteers to see what work is to be done and work to commence in October.

A summary of items discussed with Miriam Woolnough was circulated.

Grass cutting in Westfield – notes of the meeting with B&NES officers were circulated.

Resolved: to suggest to B&NES that the verges along the A367 are cut on the 4-6 week cycle and that grass spaces at Chaucer Road and Shakespeare Road (from the play area to the pit path).

47. Events

Grant presentation event – Cllr Cooper reported that Mardons committee meeting was on Thursday and she will report back on the possibility of holding the grant presentation there.

80th Anniversary of D-Day, 6th June 2024 – Discussion was held about holding an event for the 80th anniversary of D-Day on 6th June 2024. It was

Minutes subject to approval at the next meeting.

Signed Dated

Westfield Parish Council

agreed that it would be good to hold an event of some kind and ideas were circulated.

Resolved: to make this a rolling item on the agenda.

Jesters Carnival Club event at Westhill on 6th August – agreed that their public liability insurance should match the Parish Council’s of £10million and that their current insurance fell short in that it did not cover the event as a whole and omitted items such as temporary structures (gazebos) and bouncy castles.

Remembrance - Dressing of Graves – the correspondence from the Royal British Legion was noted.

48. Barriers on the footpaths at Inner Elm Terrace / Wesley Ave and Woodpecker Ave / Lynton Road

The responses to the consultations were noted. Most residents were against the installation of barriers at Inner Elm Terrace/Wesley Ave, but there was a more positive response to a barrier at Woodpecker Avenue/Lynton Road.

Resolved: (1) not to go ahead with barriers at Inner Elm Terrace/Wesley Ave
(2) to get professional accessibility advice about the best spacing for a chicane at Woodpecker Avenue/Lynton Road footpath.

49. Facilities for Young People - Meeting with the Police

It was noted that there had been no response from the police to a request for a date for the next meeting.

It was agreed to exclude the press and public on the grounds that in view of the confidential nature of the business to be transacted, it is advisable in the public interest that the press and public be temporarily excluded and they are instructed to withdraw.

The member of the public left the meeting.

50. Quotes

Bridges at Waterside Valley – There had only been one quote for the bridges at Waterside Valley. More were expected.

Dogs on leads signs –

Resolved: to accept the quote from Speed Signs for £248 + VAT each. One to be place at Norton Hill and one at Westhill.

The meeting closed at 8:47pm

Minutes subject to approval at the next meeting.

Signed **Dated**

Westfield Parish Council Planning Decisions – SEPTEMBER 2023

Date Rec'd	App No	Applicant	Location	Case Officer	Proposal	BANES Decision
16.08.2023	23/02064/OUT	Mr Mike Hill	60 Wells Road	Danielle Milsom	Erection of 2no. dwellings on land to east of existing dwelling (outline application with all matters reserved)	REFUSE



Indicates decision received since agenda printed

Parish Clerk

From: Planning Policy East <planningpolicyeast@somerset.gov.uk>
Sent: 27 July 2023 10:30
To: Collette Haynes; Andre Sestini
Subject: Mendip Local Plan Part II – Sites & Policies - adopted 2021 with revisions December 2022

Somerset Council

Cannards Grave Road,
Shepton Mallet, BA4 5BT



Somerset
Council

Mendip Local Plan Part II – Sites & Policies - adopted 2021 with revisions December 2022 Notification of policy changes to an adopted Development Plan

Dear Sir/Madam,

I am writing to notify¹ you that Somerset Council is commencing a limited update to the adopted Mendip Local Plan Part II (Sites and Policies) Plan. Mendip Council became part of the new Somerset Council on 1st April 2023. The Mendip Local Plan Parts I and II remain in force for the determining Planning applications former Mendip District area.

Following a statutory review (Judicial Review) judgement upheld on 16th December 2022, Mendip Council was subject to a High Court Order to strike out and re-consider five housing sites in the Part II Plan totalling just over 505 dwellings. This obligation has now passed to Somerset Council which has started work to re-assess these and alternative sites across the former Mendip District. The remaining sites and policies in the Mendip Local Plan Part II are not affected by this update.

An update to the Order was made on 14th July 2023 that sets dates by which consultation will take place on proposed housing sites and policies These are:

- A preferred options sites consultation by 31st December 2023 (Regulation 18);
- Publication of proposals by 31st March 2024 (Regulation 19); and
- Submission to the Planning Inspectorate for examination by 1st July 2024.

The Council is currently inviting submissions of suitable sites or confirm/update existing available land already in our records for consideration. This will be used as evidence in the re-assessment. See [Mendip Local Plan Part 2 - Call for sites - Somerset Council - Citizen Space](#). The deadline for this Mendip call for sites survey is Monday 4th September 2023.

The call for sites is only for housing sites in the former Mendip District area and capable of delivery within the Mendip Local Plan Period to 2029. The scope of the review is defined by the High Court and it is not considered the Council will be looking to allocate more than 505 dwellings in this exercise. Existing and application sites may also count towards the 505 total. No changes to the growth targets or the adopted spatial strategy are planned, and the review of site allocations will focus on the towns and primary/secondary villages identified in the Local Plan Part 1.

Information and updates on the site allocations review and legal background can be found online – see [Adopted Local Plans \(somerset.gov.uk\)](#) (select Mendip area) . If you have any further enquiries or questions, please use this email address planningpolicyeast@somerset.gov.uk.

This review is separate from Somerset Council bringing forward new a development plan for the unitary authority area. This will replace the adopted plans in the former districts. Details on the timescales for the Somerset wide plan will be published later this year.

¹ This note is being sent to statutory consultees and town/parish councils within and adjoining the Somerset East area under Regulation 18 Town & Country Planning (Local Planning) England Regulations 2012.

Your sincerely

Andre Sestini

Principal Planning Policy Officer

Somerset Council

Contact Number: 01749 341538 / Mobile: 07971 553474

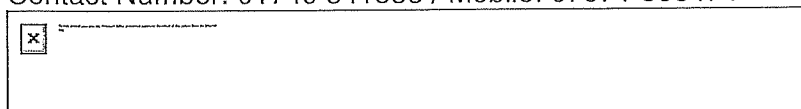

Somerset Council Disclaimer: somerset.gov.uk/disclaimer

Parish Clerk

From: Deputy Clerk
Sent: 07 August 2023 16:24
To: ~~Kate Willis~~
Cc: Parish Clerk; Admin Assistant
Subject: RE: Norton Hill Rec Play Park

Hello ~~Kate~~

I'm sorry to hear that dogs are being taken into the play park at Norton Hill, despite the signs that are there. I didn't realise that was happening.

I understand what you are saying about there being no sign on the larger gate and we will look into that.

Best regards

Tracey

Tracey Stephens
Deputy Clerk

Westfield Parish Council
The Oval Office
Cobbler's Way
Westfield
BA3 3BX

Tel: 01761 410669
Email: deputyclerk@westfieldparishcouncil.co.uk
Facebook: www.facebook.com/westfieldparishcouncil
Twitter: @westfield_pc

Please note my normal working hours are Monday 9 – 4:30, Tuesday 8:30 – 2, Wednesday 11 – 4:30

The views and comments expressed in this email are confidential to the recipients and should not be passed on to others without permission.

-----Original Message-----

From: ~~Kate Willis~~ <~~kate.willis@westfieldparishcouncil.co.uk~~>
Sent: 07 August 2023 15:52
To: Council <council@westfieldparishcouncil.co.uk>
Subject: Norton Hill Rec Play Park

Hi,

Can the signage prohibiting dogs within the fenced play park be looked at please? Owners (adults) are taking their dogs into the play park while it is busy with several families - I have seen this several times

recently. I don't think it's overly clear on the taller gate facing the car park. The little gate has a huge sign about under 12s only and no dogs though.

Thanks

~~XXXXXXXXXX~~

Sent from my iPhone

Facebook feedback on the Park Attendant

I am not aware of any consultation taking place here in Westfield

I do understand that some people are not keen on dogs, however, it would be good to understand what consultation has taken place with regards to this?

I know there are signs up, however you are able to see from the amount of people with dogs how much this area is used, and it would be nice for everyone to understand what other space has been considered for those with dogs and allowing them to run free.

As others have said, there are other significant issues that occur within the park that don't seem to be addressed, but there is a spotlight on dogs?

I know I personally have reported numerous times issues with glass / rubbish / liquids all over the paths, which is a real concern for all individuals and in particular if you have a dog on a lead on the path?

Have individuals in Westfield and in particular those who use the park been consulted with and asked for their views and opinions with regards to the consideration of a compromise with respect to this issue (as suggested in other comments)?

In addition, I'm assuming an Equality Impact Assessment has been undertaken to understand the impact this may have for individuals with protected characteristics?

For some people the only option that may be available to them to get out of the house is to let their dog have a run in the park, and whose dog may be the one thing that supports their health and well-being as well as their mental health, which is now going to be taken away from them?

I for one, have a disability and use a mobility scooter and this is the only area in Westfield that I can go with my dog and let him have a run. It has been suggested that Waterside is going to be made accessible, but to date there has been no progress with this, and I'm not aware of any other areas in Westfield that are disability friendly!

I'm assuming that all elements as well as any impact this may have on some of the parish has been considered in making this decision to ensure no one is detrimentally impacted?

I am slightly disappointed with this outcome, particularly having lived in Westfield for over 50 years and do not believe any consideration has been given to all the residents of Westfield in making this decision.

I completely agree with you. There is no argument that you can walk your dog round the roads either because the lack of drop curbs around here is also an issue especially when using a mobility scooter. X

there is absolutely nowhere, this could detrimentally impact so many people, no thought has gone into the decision. I will request a meeting with the Chair of the Parish to understand more details.

My dogs are better behaved than half the kids that are out on the fields, plus the kids racing around on mopeds over Westhill, any news on them or are dogs the only problem?

Totally agree with that as well the glass up there is really bad after a weekend ..but it's more older kids i think and unfortunately their will never be anywhere for them to go as will not be allowed to drink and smoke like they do even if they're was a youth club or something xx

Great news 🐶

What time will the park attendant be in attendance?, as I walk early 5.30-6 am, and I often see dogs running free.I am not a dog owner, but a dog lover

Finally some one listened to my argument of which I am sure was not alone in making the point get through so well done to every one

Oh love this 🐶 it will make my life so much easier as iris is nervous of dogs running up to her 🐶 I had to go through the gated play area this morning to avoid 2 dogs heading our way 🐶 I really hope this is something that carries on long term xx

perhaps money spent on somewhere for the kids of Westfield to go so that the parks & fields aren't covered with rubbish.

& regularly emptied bins would be a great place to start rather than a park attendant.

I was going to ask if the park attendant can also tackle the rubbish issue and stop the kids smashing glass all over the paths and grass while they're at it!!

Excellent news, as a responsible dog owner it annoys me when other walkers ignore the signs and let their dogs run free.

Gas-Fuelled Beacon

Bullfinch Gas Equipment

The beacon's burner-head is in the shape of a globe, surrounded by a D-Day 80 banner. It is of lightweight construction and comes assembled and complete, with the exception of the gas cylinders, which must be purchased separately. 2 x 19kg full cylinders of propane are recommended to give a full flame for a good three quarters of an hour. If you wish for less than this then one 19kg cylinder or 2 x 13kg cylinders should be sufficient. These should be full or nearly full.

These cylinders can be purchased from good lp gas (propane and butane) stockists and dealers. Do order early to ensure you can get availability.

The Gas Torch needed to light your beacon safely requires a 400g cylinder of propane with CGA600 fitting - Bullfinch No 1644 or Rothenberger or equivalent. Travis Perkins, Screwfix, Plumb Centres and some DIY stores should have these as stock items, or you can purchase from us.

The D-Day 80 Gas-Fuelled Beacon

Package contains:

- Burner unit with D-Day 80 insignia
- 2m high stand
- Ground anchor and rope for fixing the stand to the ground
- 10m hose with the regulator for connecting to the gas
- Gas torch for lighting
- Spanner
- Leak detecting fluid
- Hose assembly and Y manifold to link 2 cylinders
- Lighting and safety instructions

The above items are packed into 2 strong cartons. The tripod describes a circle area of about 1.32m diameter and the beacon has an extended height of about 2.15m.

We have made many different beacons over the years. The flames are very stable in winds and the structures are also wind stable. The beacon is supplied with a ground anchor and rope for securing to the ground if this is possible, or we would recommend the use of sandbags. Full instructions are provided for this. The beacon must be supervised by two people at all times when lit and a fire extinguisher must always be available. It is important that supervision should be undertaken by those who are competent and it is essential that a lighting trial takes place before the event to ensure that everyone is fully trained and familiar with the operation.

The price of a gas-fuelled D-Day 80 Beacon is **£549** plus VAT, including carriage to your door within UK mainland (Highlands and Islands excluded). There will be an extra charge for other areas.

Some of the benefits of this style of beacon are that it can be seen for miles once lit, is suitable for all manner of high and low locations, is easily collapsible and once used can be stored away for later use.

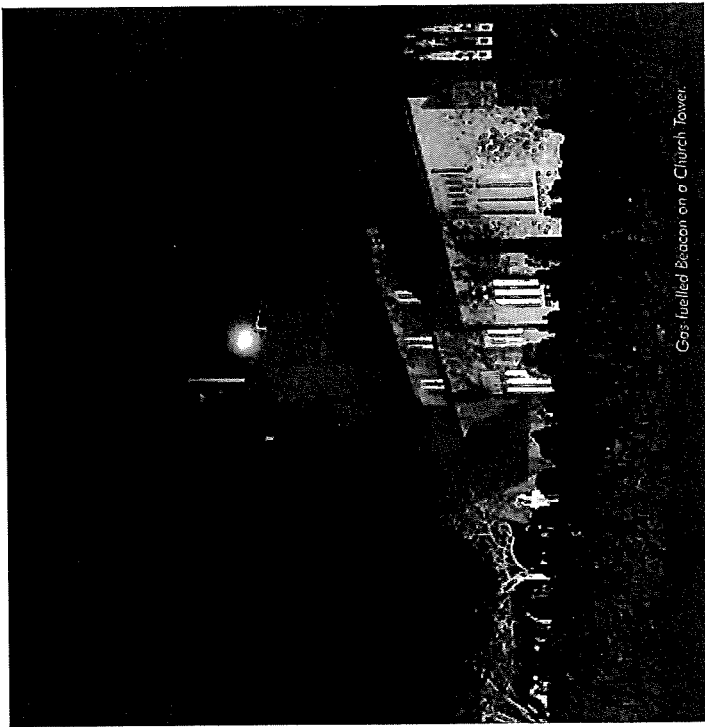

Gas-fuelled Beacon on a Church Tower.

To order your beacon please contact:
Bullfinch Gas Equipment,
Kings Road, Tyseley, Birmingham, B11 2AJ.

Tel: 0121 765 2000

Fax: 0121 707 0995

Email: sales@bullfinch-gas.co.uk

Web: www.bullfinch-gas.co.uk

Payment by cheque, BACS transfer, or Credit/Debit Card.

Please order by 30th April 2024 to guarantee delivery by 26th May. However please enquire after this date for availability.

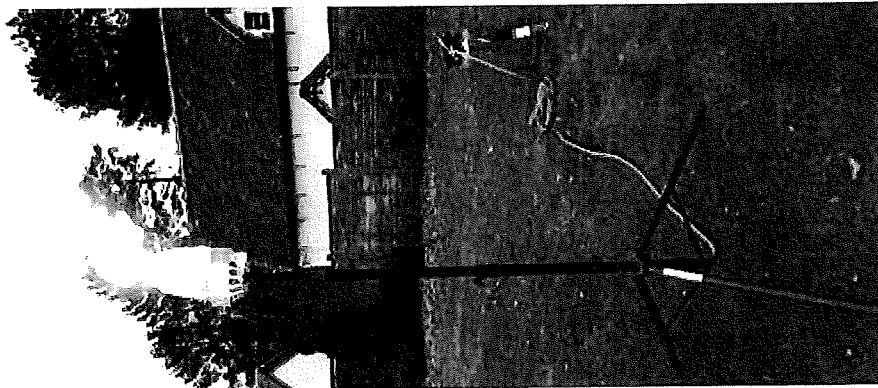

Photograph: Andrew Williams - Bullfinch Gas Equipment.



Beacon Brazier

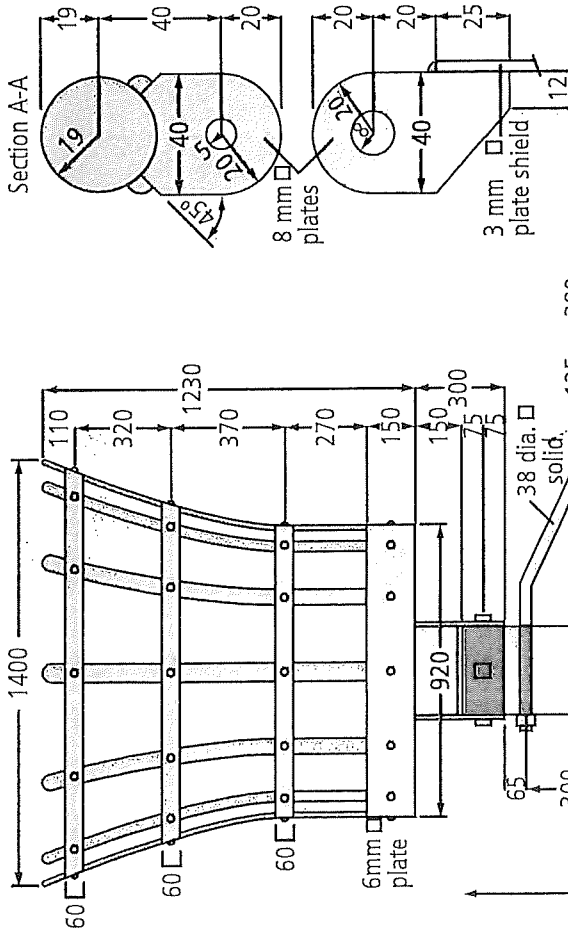

Beacon Brazier with Metal Shield

It can be built by local craftsmen and women, and may be used for future historic occasions in your community. It could be sited in a country park, on a hilltop overlooking the sea or a lake, in the centre of your town or village, and could become a tourist attraction for your area.

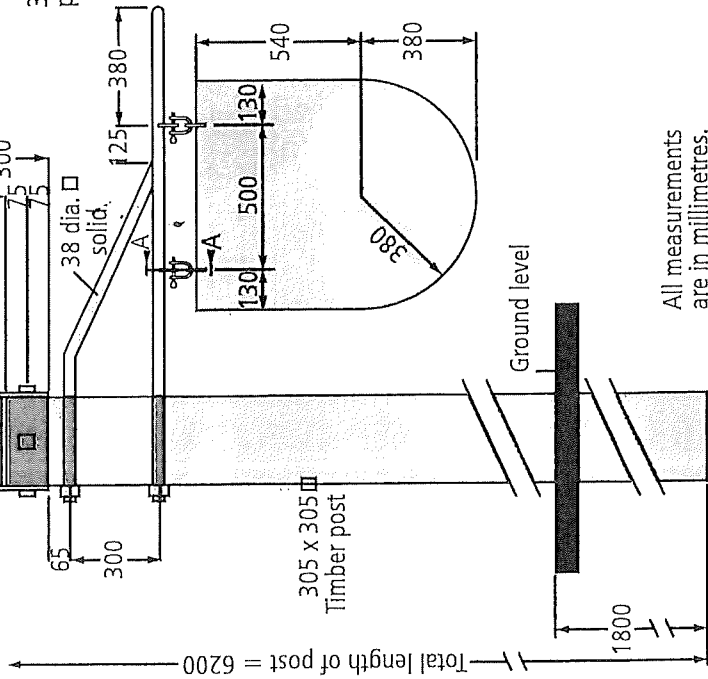

All measurements are in millimetres.

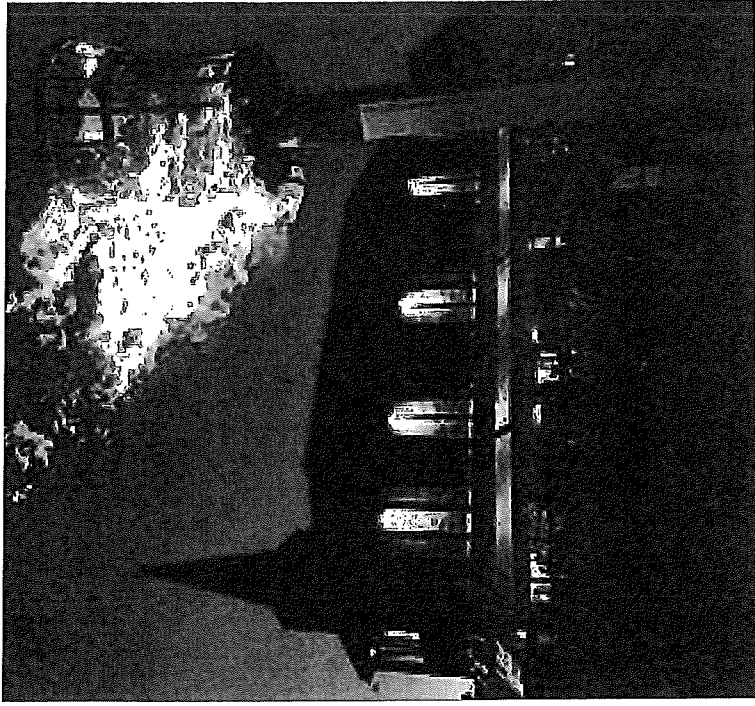

Materials Required for Beacon Construction

Wooden centre post consisting of 305mm x 305mm wooden post, 6.25 metres in length of which 2 metres goes into the ground.

Basket and fixing brackets consisting of:

- 1 x 920mm diameter steel plate.
- 1 x 4,178mm long 60mm x 5mm steel flat bar rolled into 1,330mm diameter ring.
- 1 x 3,455mm long 60mm x 5mm steel flat bar rolled into 1,100mm diameter ring.
- 1 x 2,985mm long 60mm x 5mm steel flat bar rolled into 950mm diameter ring.
- 1 x 2,922mm long 150mm x 5mm steel flat bar rolled into 930mm diameter ring.
- 12 x (approx 1,250mm long) 60mm x 5mm vertical bars (rolled to shape).
- 1 x 310mm x 310mm x 300mm high connection box welded to base of basket.
- 1 x hanging shield and support: 3.7m length of 38mm diameter solid steel rod.
- 1 x 920mm x 760mm steel plate 3mm thick 4 x connection brackets 8mm thick (see detailed drawings left).
- 2 x pins and loops.



Gas-Fuelled Beacon

21CC Group Ltd

The beacon will come ready for easy assembly, designed with a commemorative top and a special anniversary plaque underside. The beacon will burn for approximately 1 hour using two 13kg standard propane gas cylinders, which are available from most gas stockists and petrol stations around the UK. The gas assembly is easily connected to the burner by a quick release fitting. The beacon is inherently stable; however, we recommend the use of anchors on soft ground or sandbags on hard ground for additional stability. Full set-up instructions are included within the pack and we recommend a trial set-up and lighting before the actual event to familiarise yourself with the set-up and operation. We have included two long-reach lighting sticks so that you can practice lighting the beacon in advance. We would also recommend that a fire extinguisher is available when lighting the beacon and whilst it is burning and that two people are always present.

The D-Day Beacon package contains:

- Assembly, lighting and safety instructions
- 2m high stand and burner
- 5m hose with the regulator for connecting to the gas
- Two long-reach lighting sticks
- Spanner and leak detection fluid
- Hose and Y splitter manifold to link 2 cylinders
- No additional connections required - all you need is in the box

Beacon Price:

The price of our beacon is **£549** + vat, including carriage within the UK mainland. An additional charge may be applied for other areas.

Ordering & Payment

To order your D-Day 80 beacon, please contact 21CC Group Ltd by phone; **0131 331 4509** or email our beacon team on beacons@21ccgroup.com. Additional information can be found on our website at www.21ccgroup.com/D-Daybeacons. Payment can be made in all the usual ways including BACS, cheque and credit/debit card. Orders received before the **3rd of May 2024** will be delivered by **31st May 2024**. All orders received after 3rd of May 2024 will be accepted on a case-by-case basis depending on stock levels available.

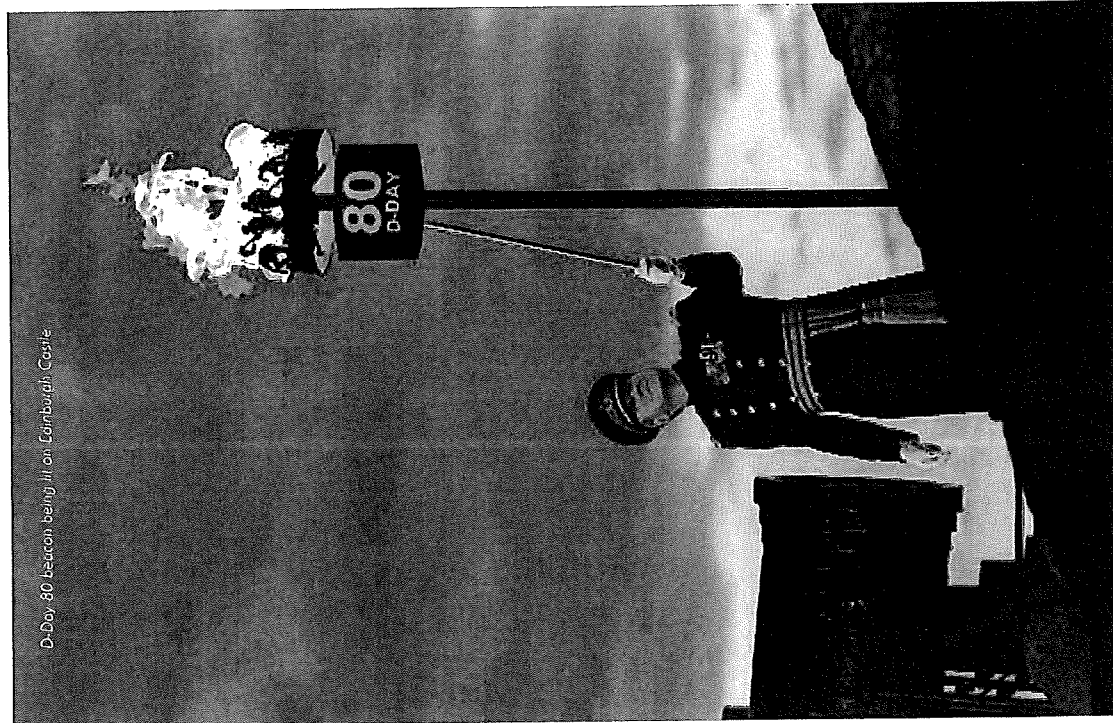

D-Day 80 beacon being lit on Edinburgh Coast

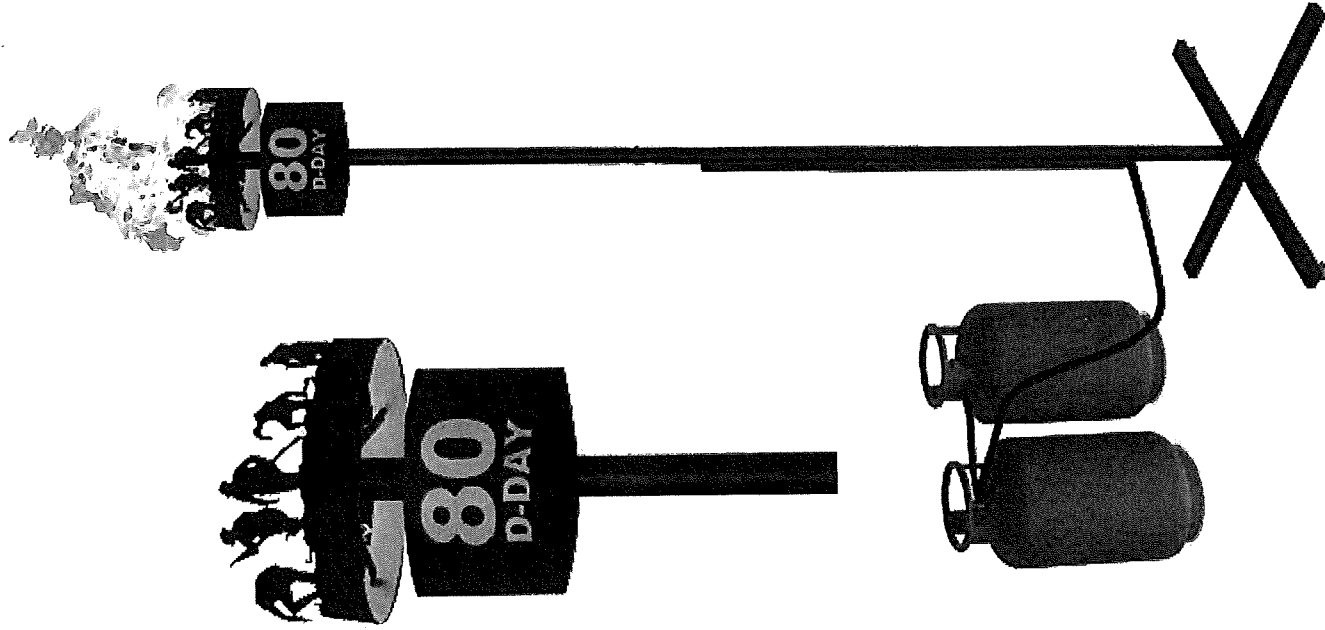

How to take part and register your involvement

Step 1: To confirm your involvement and make important communication as easy as possible please register your involvement, providing the information below, direct to brunopeek@mac.com as soon as possible please, but **no later than 30th May 2024**.

If your event is a private occasion and NOT open to the public, and you do not want your involvement shown on any public or media listing, it is important that you confirm this when providing information. Your participation will still be noted as part of this historic occasion but NOT made public. However, if your event IS open to the public, your contact details will be shared with the media so that they can contact you direct to arrange any publicity and/or coverage of your event.

Name and Job title of contact/coordinator

Name of Council, School, Pub, Organisation etc

Name of Country - ie England, Scotland, Wales, Northern Ireland, Channel Island, Isle of Man, UK Overseas Territory

Name of County

Name of Parish, Town, Borough, District, Community, or County Council etc

Full Postal address including post code

Telephone number - Landline/Mobile

Email

Will you be having Fish & Chips as part of your Beacon lighting YES/NO

Will your School be involved in the reading of the Poem at

11am, found YES/NO

Will your School/Pub/etc/ event be involving the eating of Fish & Chips during the day YES/NO

Will your event involve the reading of the International Tribute at 9.15pm YES/NO

Public event

Private event

Public or private event & legal essentials

Ensure you have undertaken all the legal essentials and safety requirements on **page 34** before lighting your beacon. Alert the emergency services, including the Fire Brigade, undertake any

risk assessments required and ensure everyone involved is happy and familiar with your plans. **(This is your responsibility as coordinator)**. In the event of dry weather, high winds and a heightened wildfire risk on the day of the event, please carefully consider scaling back initial plans where appropriate.

Beacon lighting ceremony - 6th June 2024

Please light your Beacon and undertake the Nation's Tribute using the wording found on page 20 at 9.15pm.

The Beacon lighting ceremony and Nation's Tribute should be undertaken as follows:

Step 2: Invite your Lord Lieutenant, DL, Lord Mayor, Sheriff, High Steward, Lord Provost, Chairman or leader of the Council or another of your choice from within your local community to light your Beacon and undertake the Nation's Tribute at **9.15pm**, using the wording found on **page 20**. Alternatively, you may wish to organise a competition in partnership with your local media, with the winner having the honour of lighting the beacon and the Nation's Toast.

Step 3: You might consider having professional photographs taken during your event. Immediately after, please send no more than two high quality, copyright-free photographs to brunopeek@mac.com, including the name of the photographer, the beacon location, county, country and postcode, along with the name of the council or organisation.

Step 4: If appropriate, use social media channels - Twitter, Facebook etc - to promote your event. On Facebook, post photographs of your beacon lighting ceremony.

Step 5: Publicise your event. We will provide you with a Press Release template which you can localise, providing as much information as you wish regarding your event, but including your contact details. You can send this to your local media to enable them to get in touch with you direct.

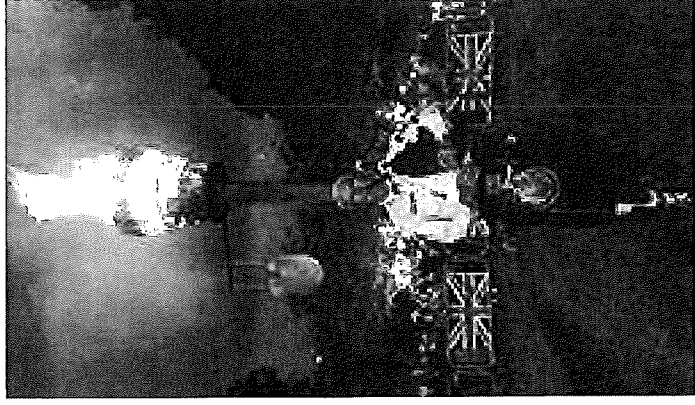
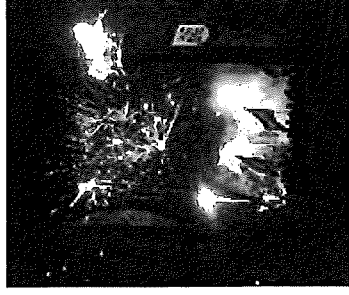

How to take part and register your involvement

Step 1: To confirm your involvement and make important communication as easy as possible please register your involvement, providing the information below, direct to brunopeek@mac.com as soon as possible please, but **no later than 30th May 2024.**

If your event is a private occasion and NOT open to the public, and you do not want your involvement shown on any public or media listing, it is important that you confirm this when providing information. Your participation will still be noted as part of this historic occasion but NOT made public. However, if your event IS open to the public, your contact details will be shared with the media so that they can contact you direct to arrange any publicity and/or coverage of your event.

Name and Job title of contact/coordinator
 Name of Council, School, Pub, Organisation etc
 Name of Country - ie England, Scotland, Wales, Northern Ireland, Channel Island, Isle of Man, UK Overseas Territory
 Name of County
 Name of Parish, Town, Borough, District, Community, or County Council etc
 Full Postal address including post code
 Telephone number - Landline/Mobile
 Email

Will you be having Fish & Chips as part of your Beacon lighting YES/NO
 Will your School be involved in the reading of the Poem at 11am, found YES/NO
 Will your School/Pub/etc/ event be involving the eating of Fish & Chips during the day YES/NO
 Will your event involve the reading of the International Tribute at 9.15pm YES/NO

Public event
Private event

Public or private event & legal essentials

Ensure you have undertaken all the legal essentials and safety requirements on **page 34** before lighting your beacon. Alert the emergency services, including the Fire Brigade, undertake any

risk assessments required and ensure everyone involved is happy and familiar with your plans. **(This is your responsibility as coordinator).** In the event of dry weather, high winds and a heightened wildfire risk on the day of the event, please carefully consider scaling back initial plans where appropriate.

Beacon lighting ceremony - 6th June 2024

Please light your Beacon and undertake the Nation's Tribute using the wording found on page 20 at 9.15pm.

The Beacon lighting ceremony and Nation's Tribute should be undertaken as follows:

Step 2: Invite your Lord Lieutenant, DL, Lord Mayor, Sheriff, High Steward, Lord Provost, Chairman or leader of the Council or another of your choice from within your local community to light your Beacon and undertake the Nation's Tribute at **9.15pm**, using the wording found on **page 20**. Alternatively, you may wish to organise a competition in partnership with your local media, with the winner having the honour of lighting the beacon and the Nation's Toast.

Step 3: You might consider having professional photographs taken during your event. Immediately after, please send no more than two high quality, copyright-free photographs to brunopeek@mac.com, including the name of the photographer, the beacon location, county, country and postcode, along with the name of the council or organisation.

Step 4: If appropriate, use social media channels - Twitter, Facebook etc - to promote your event. On Facebook, post photographs of your beacon lighting ceremony.

Step 5: Publicise your event. We will provide you with a Press Release template which you can localise, providing as much information as you wish regarding your event, but including your contact details. You can send this to your local media to enable them to get in touch with you direct.

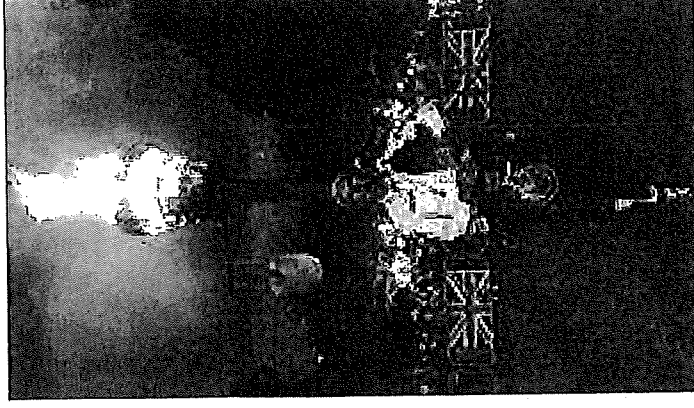
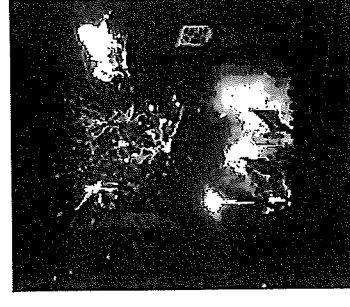

Morning Alison

We emailed in May this year regarding the footpath from Lynton Road to Woodpecker Avenue in Westfield and you confirmed that this is adopted land.

Following meetings with the Police and a consultation with local people, we would like to go ahead and put in chicane style barriers to slow down / deter pit bikes. We take on board what you say in relation to not being able to do anything to prevent motorcyclists without impacting legitimate users of the path. However, the aim is simply to deter / slow down the bikes and of course keep the pathway fully accessible.

In terms of finance, we are happy to look at sources of funding, however first we would need to go out for quotes. So the first question is are you in agreement that the Parish Council can install the chicane style barriers and if so, please can you point me towards a spec which distances the barriers so that they are still accessible for people in mobility scooters?

Your help in this is very much appreciated and best wishes,

Lesley

Lesley Close
Parish Clerk
Westfield Parish Council
The Oval Office
Cobblers Way
Westfield BA3 3BX

01761 410669

Please note my working hours are Monday to Thursday 9am to 2pm.

www.westfieldparishcouncil.co.uk

Twitter: @westfield_pc

www.facebook.com/westfieldparishcouncil

Privacy Notice

This Council recognises that it has a duty to people whose information it holds to treat that information in accordance with statute. View our Privacy Policy which explains how we use any personal information we collect about you - <https://www.westfieldparishcouncil.co.uk/privacy-notice/>

Confidentiality Notice

This email and its attachments are confidential and are intended for the above named recipient only. If this has come to you in error, please notify the sender immediately and delete this email from your system. You must take no action based on this, nor must you copy or disclose it or any part of its contents to any person or organisation. Statements and opinions contained in this email may not necessarily represent those of the Council. As a public body, the Council may be required to disclose this email under the Freedom of Information Act 2000, unless the information in it is covered by one of the exemptions in the Act.



Parish Clerk

From: Alison Sherwin <Alison_Sherwin@BATHNES.GOV.UK>
Sent: 09 August 2023 13:38
To: Parish Clerk
Subject: RE: Pathway from Lynton Road to Woodpecker Avenue, Westfield

Hi Lesley

I would not recommend staggered (chicane) barriers for the reasons set out below. This is cycle guidance LTN 1/20 which are the government design standards we use and in section 8.3.4 it also refers to mobility scooters.

Bollards are suggested as an alternative at 1.5m spacing (8.3.5) if a access control is required. However, if you feel a staggered barrier is the best solution to deter motorcyclists the gap should be 1.5m minimum and the barriers should be set a minimum of 1.5m apart or could you install one barrier with a 1.5m gap?

Regards

Alison

Alison Sherwin

Principal Engineer Active Travel

Bath & North East Somerset Council

My working days are all day Tuesday, Wednesday and Thursday mornings

Telephone: 01225 394406

Email: Alison_sherwin@bathnes.gov.uk

www.bathnes.gov.uk

www.twitter.com/bathnes

Improving People's Lives



Bold



Empowered



Supportive

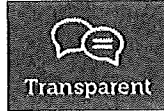

Transparent

Please consider the environment before printing this email

Alternative signs with legends such as 'Share with Care' or 'Give Way to Pedestrians' signs may be used but these are not prescribed traffic signs and must not be used on the public highway. Periodic information campaigns can help remind all users to be considerate to others.

8.2.10 In rural and suburban areas, there may be various rights of way and permitted paths away from the highway. The legal status of a route cannot easily

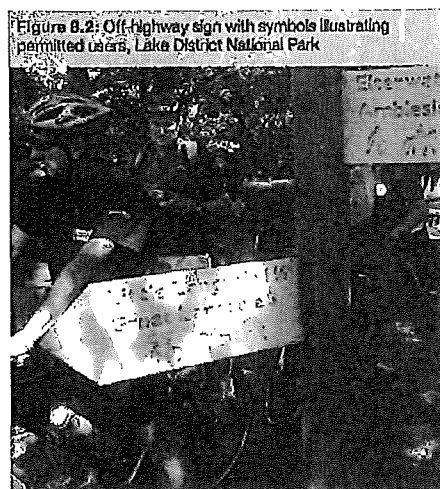

be addressed in another way.

8.3 Access controls

8.3.1 Access controls can reduce the usability of a route by all cyclists, and may exclude some disabled people and others riding nonstandard cycles. There should therefore be a general presumption against the use of access controls unless there is a persistent and significant problem of antisocial moped or motorcycle access that cannot be controlled through periodic policing.

8.3.2 Access controls that require the cyclist to dismount or cannot accommodate the cycle design vehicle are not inclusive and should not be used.

8.3.3 Access controls should not be required simply to control cyclists on the approach to a road or footway crossing. It will normally be sufficient to provide good sightlines and road markings so that cyclists clearly understand the need to take care and give way to pedestrians and other traffic at such points.

8.3.4 Chicane barriers cannot be used by people on tandems, tricycles, cargo bikes and people with child trailers. They may also be inaccessible to some types of wheelchair and mobility scooter. An access control that requires cyclists to dismount will exclude hard cyclists and others who cannot easily walk. Barriers fitted with plates that are designed to be narrower than motorcycle handlebars will also leave a gap that is narrower than many larger cycles. This will require cyclists to stop and

37 Guidance on the Use of Tactile Paving Surfaces, published by DfT

Cycle Infrastructure Design

put a foot down to pass through, which can be difficult when carrying children or heavy luggage.

8.3.5 An alternative method is to provide bollards at a minimum of 1.5m spacing, which allows users to approach in a straight line whilst permitting all types of cycle and mobility scooter to gain access. If access is required by wider maintenance vehicles, a lockable bollard can be used (see Figure 8.3).

8.3.6 Bollards and barriers should contrast with the background and may be fitted with retroreflective material to ensure they can easily be seen in all conditions.

Figure 8.3: Simple removable bollard on cycle track, Scottish Borders



8.3.7 Where it is necessary to control the movement of livestock a cattle grid should be used, in preference to a gate which will cause delay to cyclists. Experience in Cambridge showed that a cattle grid with closely-spaced (100mm) threaded rod bars can be crossed

From: Parish Clerk <parishclerk@westfieldparishcouncil.co.uk>

Sent: 07 August 2023 12:34

To: Alison Sherwin <Alison_Sherwin@BATHNES.GOV.UK>

Subject: FW: Pathway from Lynton Road to Woodpecker Avenue, Westfield

Hi Alison

Parish Clerk

From: ~~Alistair Perry, Alistair.Perry@wessexwater.co.uk~~
Sent: 02 August 2023 15:24
To: Council
Subject: Pit Bikes On Footpath At End of Chaucer Road

Good Afternoon,

I saw recently on Facebook that you were looking at putting in a barrier on the path between inner Elm Terrace and Wesley Avenue.

We've been having the same issue with pit bikes using the footpath at the end of Chaucer Road to shortcut from the main road, it's becoming quite dangerous for dog walkers of people on the footpath.



I informed BANES council but they told me to speak to the police. Are we able to get a similar barrier installed on the crossing point of Old Pit Road.

Kind Regards,

~~Alistair Perry~~

This email is confidential. If you are not the intended recipient, you must not copy, distribute, disclose or use the information contained in it. If you have received this communication in error, please tell us immediately by return email and then delete the email and any copies of it from your computer system. Thank you.

Wessex Water Services Limited, Registered in England No 2366648. Registered Office – Wessex Water Operations Centre, Claverton Down Road, Claverton Down, Bath, BA2 7WW

Parish Clerk

From: Eleanor Jackson (Cllr) <Eleanor_Jackson@BATHNES.GOV.UK>
Sent: 02 August 2023 14:19
To: Parish Clerk
Subject: RE: Weekly E Mail - 2nd August 2023

Dear Lesley

I would love to join in the bulb planting in Glebelands. You don't fancy doing Shakespeare Road as well? I can try to persuade Curo to pay for the bulbs At the Elm Tree Avenue Memorial stone.

Remembrance Tide. Saturday 11 November 10.50 – 11.10 Informal act of remembrance led by Revd Ian Rousell with silence and Last Post.

afterwards in the church hall

Coffee available before and

Sunday 12 November. C 10.55 Formal Act of Remembrance and laying of wreaths led by a Methodist Minister

church service which starts at 10.30 indoors at Trinity

As part of the Methodist

Methodist Church All

welcome.

This is organised by Christians Together in Radstock and Westfield in partnership with Westfield parish Council and Curo Housing Association. The ceremonies in Midsomer Norton and Radstock organised by the British Legion will take place as usual.

I had a chat with Ian yesterday. He is going to contact you about the 'dressing of the graves' – to which he is opposed. He wants WPC's view before he writes to the Legion. He is going to talk to the schools and the uniformed organisations about their involvement. The Graveyard at St Nick's is hugely improved, now that the new force is at work.

Ian's point is that we have too many Radstock and Westfield men who died in France and are buried there, apart from those who have no known grave, and the burial in Iraq of one Westfield man.

The map of the Waterside is still hanging in the church hall because there has been a great deal of interest in it. Is it too late for further suggestions.

Finally, there is huge disturbance on the batch caused by bikers. They come in from Linden Close. Is there anything we can do about this? The police have been called to Haydon, but refuse to do anything. They seem to think that the damage to the paths is nothing (there are deep ruts) and it is all quite harmless!!

Best wishes
Eleanor

Parish Clerk

From: Parish Clerk
Sent: 03 August 2023 12:32
To: 'Eleanor Jackson (Cllr)'
Cc: Deputy Clerk; Admin Assistant; 'Diana Cooper'; 'Eleanor Jackson'; 'Geoff Fuller'; 'James Honess'; 'Pat Williams'; Paul Millard; 'Ron Hopkins'
Subject: Bikes on the batch
Attachments: Linden Close entry to Waterside Valley Aug 2023.jpg; Linden Close entry to green space not owned by Parish Council.jpg

Hi Eleanor

Thank you for your email asking if anything can be done to stop bikes on the Haydon Batch which gain access from Linden Close.

I have taken two photos of the entrance, attached.

The first is the entrance to the Parish Council owned land at Linden Close. I shall put this on the next E&D agenda in case the Parish Council would like to consider specific barriers to stop or deter bikes. I also attach a photo of the adjacent entrance at Linden Close which leads to open space not owned by the Parish Council. Is there a danger that putting a barrier in the first location will not actually solve the problem, because of the second access point? In addition I think there are quite a number of other access points on to Waterside Valley – Redwood Close, Chestnut Close etc I think the wider picture should be considered by the Committee before committing public funds to a single barrier at Linden Close.

I shall put this on the E&D agenda.

Best wishes,

Lesley

Lesley Close
Parish Clerk
Westfield Parish Council
The Oval Office
Cobblers Way
Westfield BA3 3BX

01761 410669

Please note my working hours are Monday to Thursday 9am to 2pm.

www.westfieldparishcouncil.co.uk

Twitter: @westfield_pc

www.facebook.com/westfieldparishcouncil

Privacy Notice

This Council recognises that it has a duty to people whose information it holds to treat that information in accordance with statute. View our Privacy Policy which explains how we use any personal information we collect about you - <https://www.westfieldparishcouncil.co.uk/privacy-notice/>

Under close
entrance
to
waterside
way.
Adjacent
to this is
another
entrance
(over leaf)
to open
green
space
NOT
owned by
the
parish.
Council



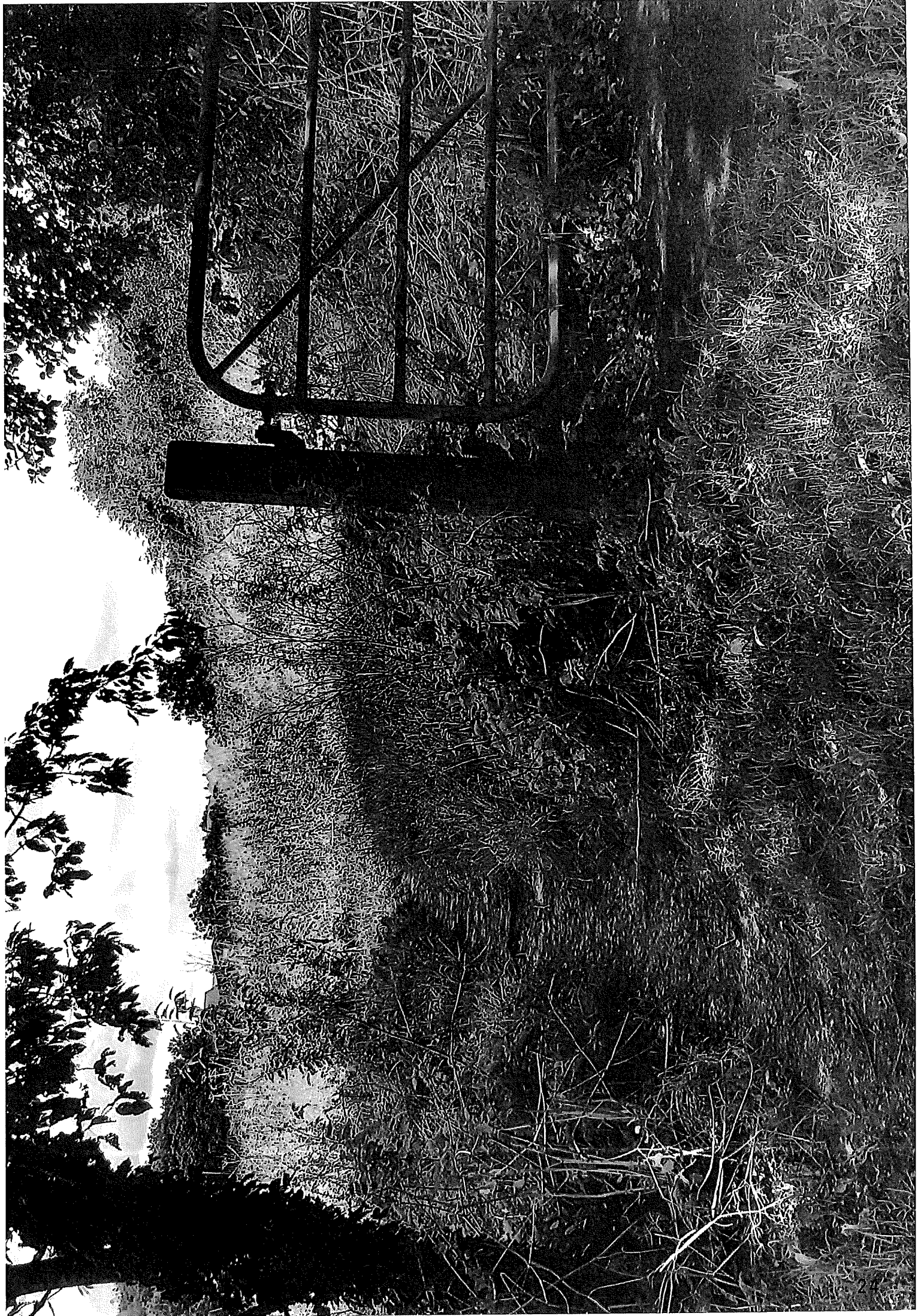



#LoveParks



What we did:

'Lunchtime litter pick' – at Norton Hill Recreation Ground on Tuesday 1st August at midday

'Park Bingo' – forms were available to print from our website and collect from reception at The Oval Office

'Photography competition' – entrants were invited to send photos of green spaces or parks in Westfield for a chance to feature in our quarterly magazine, the Westfield Warbler, on our website and social media channels

'Have your say' – we created a short survey to learn more about what the community think of our local parks and green spaces

Success of the events:

'Lunchtime litter pick'

Caitlin and Tracey did a litter pick at Norton Hill Rec. They were not joined by any volunteers however they took photos and uploaded them to Facebook and they were generally well received. Facebook insights can be seen here:

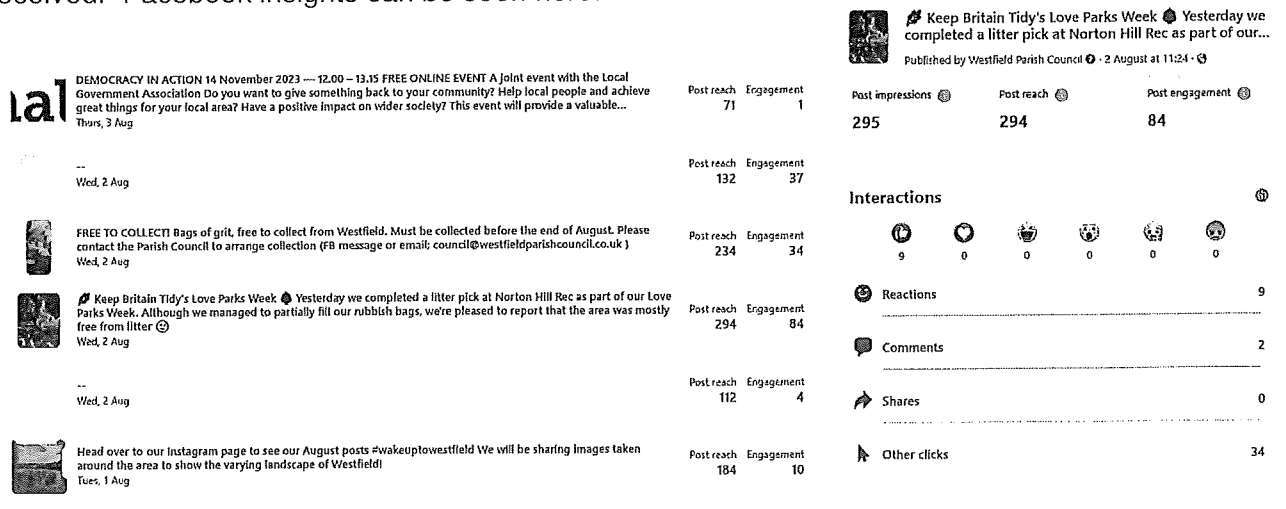

Facebook statistics show that this was one of our most engaged with posts that week.

'Park Bingo'

It's hard to determine how many people engaged with the bingo as it was able to be downloaded freely from our website.

'Photography competition'

Unfortunately, we didn't have any entries.

'Have your say'

The survey was completed by 16 people. Please see attached results.

It was interesting to note that 11/16 people would not know who to contact to discuss something related to the local parks and green spaces, even though there is signage in the recreation grounds and the Parish Council's purchase of Waterside Valley has been well publicised.

Conclusion

Overall, the response to the Love Parks Week was positive and encouraged community engagement, even if this was mainly via social media.

We liaised with Somer Valley Rediscovered who were also taking part in the campaign, building the Parish Council's local connections.

Campaigning for appropriate awareness weeks will support connections with various groups within the community and over time will grow in engagement.

Parks and green spaces in Westfield

Q1

Customize Save as

Do you think parks and green spaces are important to the community?

Answered: 16 Skipped: 0

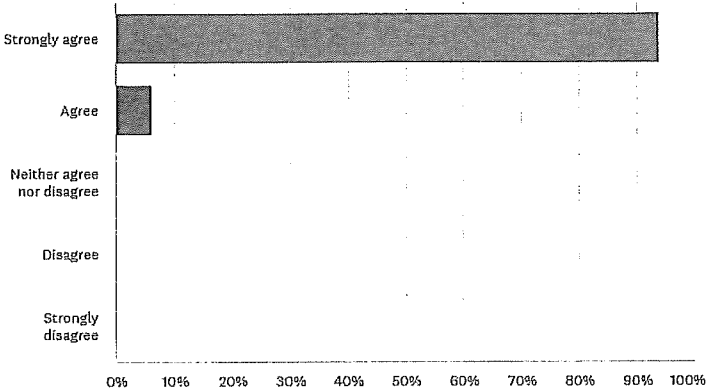

ANSWER CHOICES	RESPONSES	
Strongly agree	93.75%	15
Agree	6.25%	1
Neither agree nor disagree	0.00%	0
Disagree	0.00%	0
Strongly disagree	0.00%	0
TOTAL		16

Q2

Customize Save as

Do you feel safe accessing local parks and green spaces?

Answered: 16 Skipped: 0

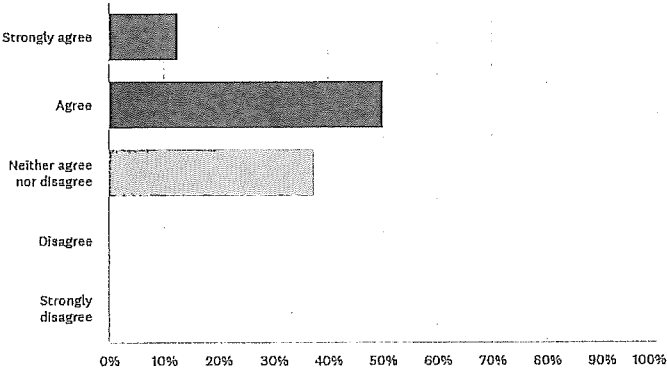

ANSWER CHOICES	RESPONSES	
Strongly agree	12.50%	2
Agree	50.00%	8
Neither agree nor disagree	37.50%	6
Disagree	0.00%	0
Strongly disagree	0.00%	0
TOTAL		16

Q3



Do you feel that the parks and green spaces offer things for a range of people within the local community?

Answered: 16 Skipped: 0

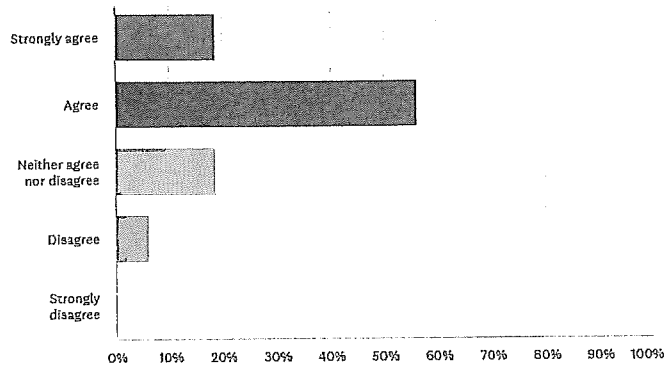

ANSWER CHOICES	RESPONSES	
Strongly agree	18.75%	3
Agree	56.25%	9
Neither agree nor disagree	18.75%	3
Disagree	6.25%	1
Strongly disagree	0.00%	0
TOTAL		16

Q4



Would you know who to contact if you wanted to discuss something related to local parks and green spaces?

Answered: 16 Skipped: 0

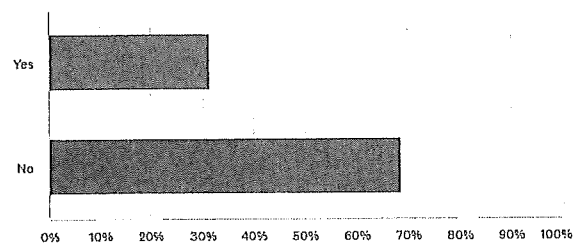

ANSWER CHOICES	RESPONSES	
Yes	31.25%	5
No	68.75%	11
TOTAL		16

Facebook statistics

Ad account: Westfield Parish Council 2384590474... ▾

📅 1 Aug 2022 - 1 Aug 2023 ▾



Reach

Compare your reach from this period to the See more about your content performance previous one.

Facebook reach ⓘ
10,981 ↑ 48.8%

Paid reach ⓘ
0 0.0%

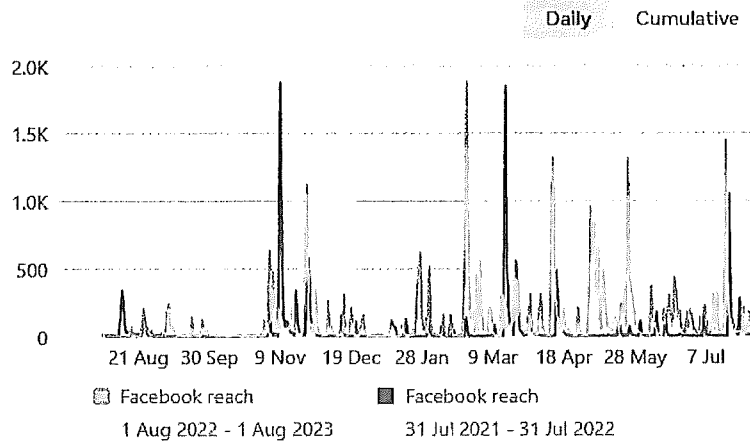

Ad account: Westfield Parish Council 2384590474... ▾

📅 1 Aug 2022 - 1 Aug 2023 ▾

Reach

Compare your reach from this period to the See more about your content performance previous one.

Facebook reach ⓘ
10,986 ↑ 48.3%

Paid reach ⓘ
0 0.0%

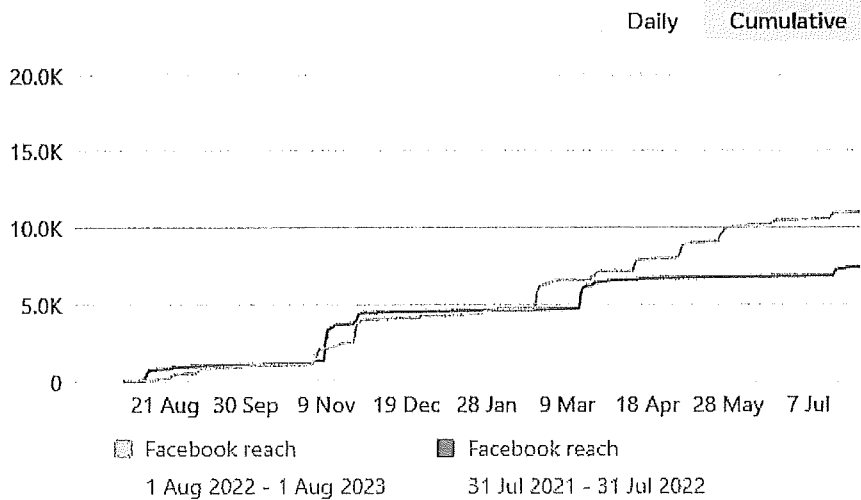

Results

Facebook reach ⓘ

10,986 ↑ 48.3%

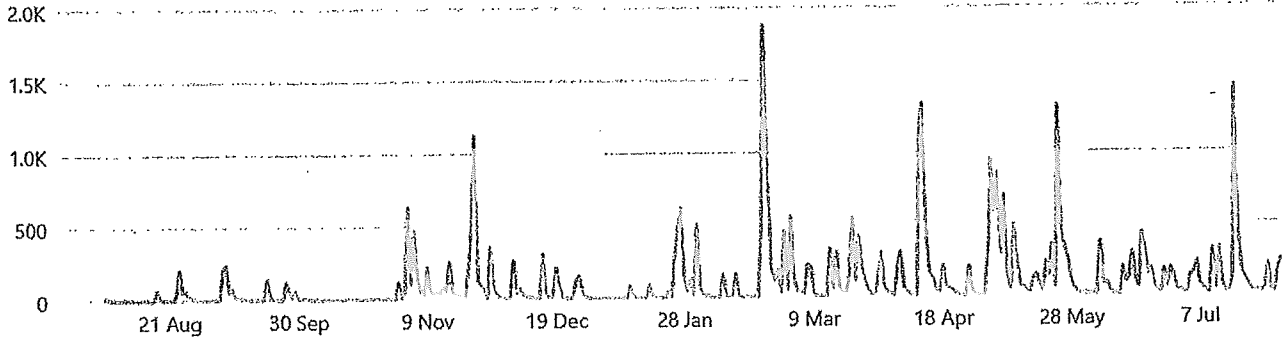

Facebook visits ⓘ

2,538 ↑ 480.8%

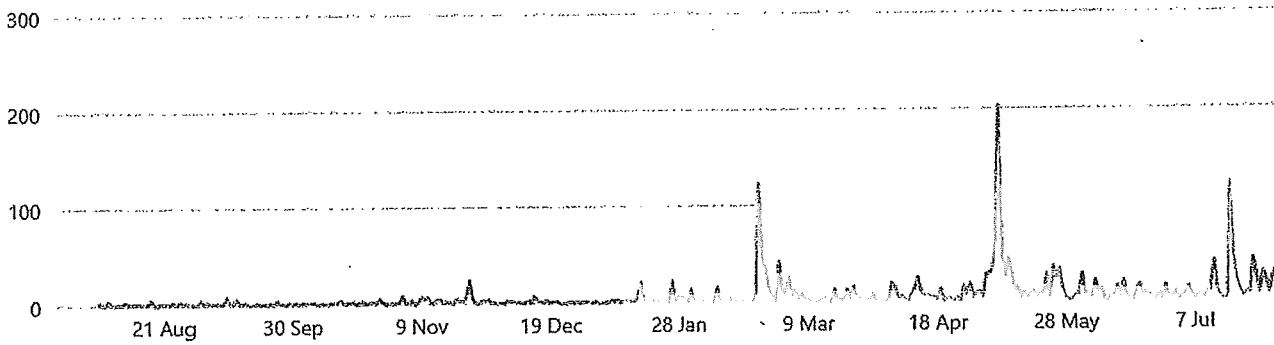

Facebook Page new likes ⓘ

31 ↑ 19.2%

